

(No Model.)

F. McCLURE.
CHUCK FOR TURNING LATHES.

No. 436,459.

Patented Sept. 16, 1890.

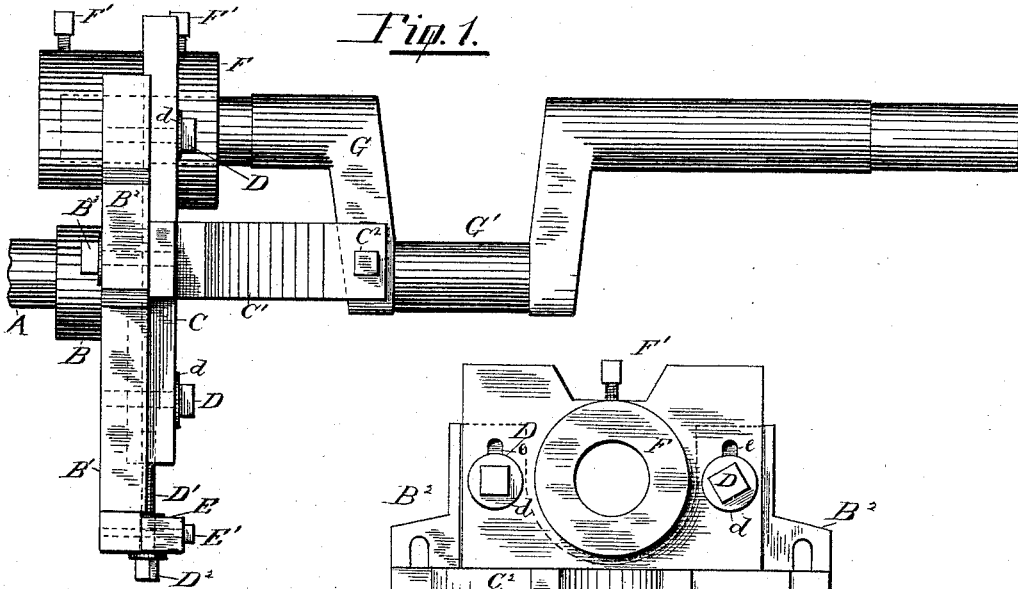

Fig. 1.

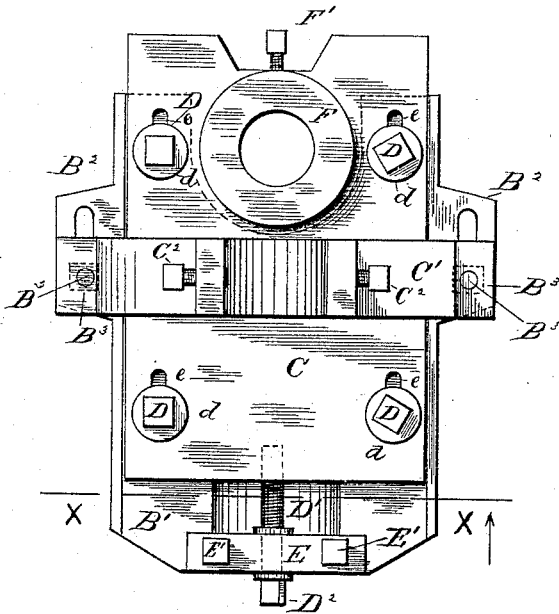

Fig. 2.

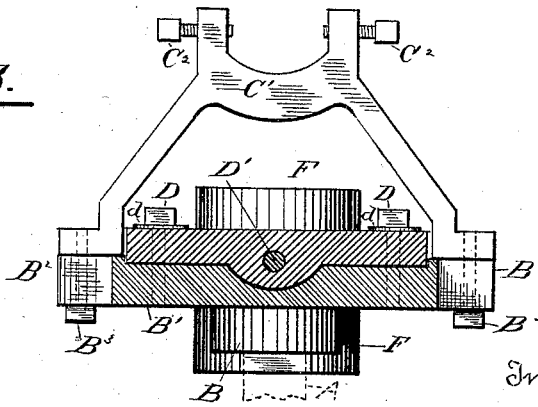

Fig. 3.

Witnesses

Alex. C. Villahan.
Orniston T. Tye.

Inventor

Frank McClure,
By C. D. Stowe,

Attorney

UNITED STATES PATENT OFFICE.

FRANK McCLURE, OF STOCKTON, CALIFORNIA, ASSIGNOR OF ONE-HALF
TO AMERICUS M. ABBOTT, OF SAME PLACE.

CHUCK FOR TURNING-LATHES.

SPECIFICATION forming part of Letters Patent No. 436,459, dated September 16, 1890.

Application filed April 24, 1890. Serial No. 349,246. (No model.)

To all whom it may concern:

Be it known that I, FRANK McCLURE, a citizen of the United States, residing at Stockton, in the county of San Joaquin and State of California, have invented certain new and useful Improvements in Chucks for Turning-Lathes; and I do hereby declare the following to be a full, clear, and exact description of the invention, such as will enable others skilled in the art to which it appertains to make and use the same.

My invention relates to an appendage to a lathe, and is of the class called "chucks;" and it consists in such devices and combination of devices as will permit of the portion of the crank-shaft to be turned being placed in a direct line with the lathe-spindle, and being grasped in the jaws of the chuck simply and expeditiously.

In the drawings, Figure 1 is a side elevation of my improved chuck, showing a crank-shaft attached and in position to be turned. Fig. 2 is a right-hand elevation of the same with the crank-shaft removed. Fig. 3 is a section through line X X, Fig. 2.

Similar letters of reference indicate corresponding parts in the several views.

A is the usual lathe-spindle.

B is the hub that is screwed onto the spindle A.

B' is the main body of the chuck, and B² are lugs, one on each side of the body B' and provided with slots.

A bridge C' is secured to the lugs B² by bolts B³ at the slots of the lugs, which permit it to be moved back and forth and thus be adjusted to different sizes of crank-shafts. The top of the bridge C' is provided with jaws having threaded eyes for the reception of set screws C² for grasping the crank-shaft G at its elbow and near the portion G' to be turned.

A slide C, provided with a slot *e* at each corner, is attached to the body B' by bolts D inserted through the slots *e* and carrying washers *d*, and has at its top a hub F for the reception of the end of the crank-shaft G, which is held firmly in the hub F by set-screws F'.

The slide C is moved back and forth, as is required, by an adjusting-screw D', provided

with a head D² for turning the same. The screw D' is held in place by a guide-block E, provided with a threaded eye and secured to the body B' by bolts E'.

To gage my improved chuck for use I attach it at the hub B to the lathe-spindle and adjust the slide C and the adjustable bridge C', so that the hub F will receive the end of the crank-shaft G, and the jaws of the bridge C' will grasp the elbow of such shaft. The bolts D and B³ are then screwed up tightly, and the set-screws F' and C² likewise, thus holding all the various parts firmly in position for turning the part G' of the crank-shaft G. The slide C has a longitudinal oval ridge at its center, parallel with and fitting into channel in the face of the body B'. The slide C is also slightly dovetailed into the body B', thus insuring steady action. The ridge of the slide C also furnishes the foundation for the attachment of the adjusting-bolt D'.

Having thus described my invention, what I claim as new is—

1. In a chuck, the combination, substantially as described, of the main body B', provided with the slotted lugs B², the bridge C', attached to the body B' at the slots of the lugs B² by the bolts B³, the slide C, provided with slots *e* at each corner and secured to the body B' by the bolts D, the body B' provided with the hub B for the reception of the lathe-spindle, the slide C provided with the hub F for the reception of the end of the crank-shaft, and the bridge C' being provided with the jaws having the set-screws C² for the reception of the elbow of the crank-shaft, and the slide C having the adjustable screw D' secured to the end of the body B' by the guide-block E and its bolts E'.

2. The combination of the body B', having the hub B and slotted lugs B², with the adjustable bridge C', provided with jaws, and with the slide C, having the hub F, the slide C and bridge C' being suitably secured to the body B', and suitable means for adjusting the position of the slide C and bridge C', all substantially as described.

3. As a new article of manufacture, a chuck composed of the main body B', provided with

suitable means of attaching to the lathe-spindle, so that the part of the crank-shaft to be turned may be in a direct line therewith, the slide C, adjustably attached to the body B' and provided with the hub F and its set-screws for the reception of the end of the crank-shaft, and the bridge C', adjustably attached to the body B' and provided with jaws having the set-screws C² for grasping

the crank-shaft at its elbow, all substantially as described and set forth.

In testimony whereof I affix my signature in presence of two witnesses.

FRANK McCLURE.

Witnesses:

E. BEECHER STOWE,
EDRIS B. MYERS.